



# Titan

## 5500, 8000

INSTALLATION AND OPERATING INSTRUCTIONS.  
READ INSTRUCTIONS CAREFULLY BEFORE ATTEMPTING INSTALLATION.

FIG.1

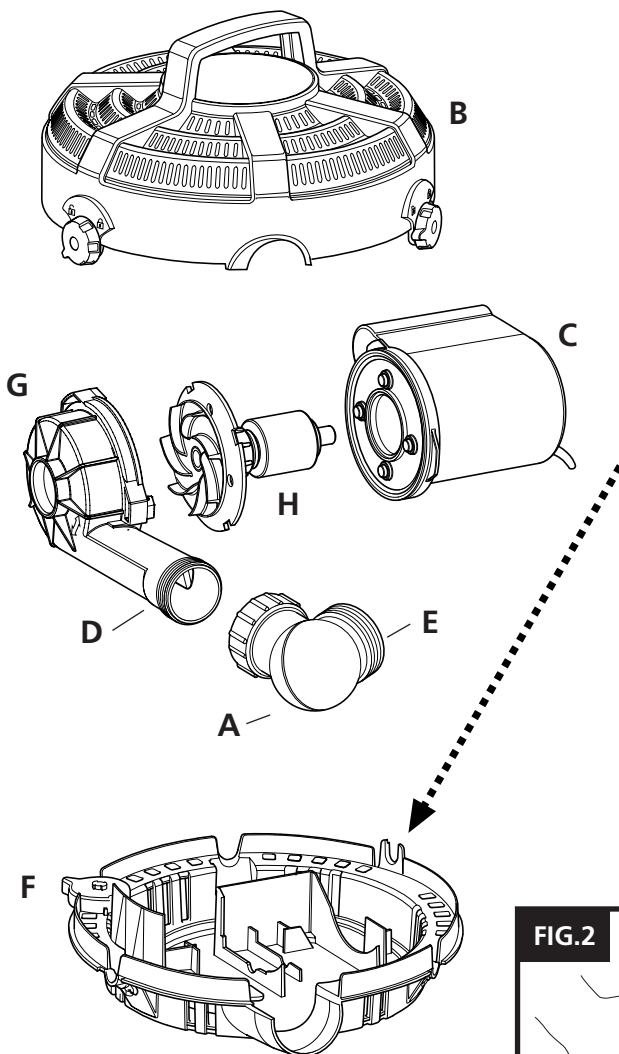
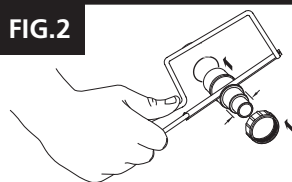

FIG.2



## ATTENTION

**AUTOMATIC CUT-OUT.** To help ensure your pump's long life and to prevent damage, it is fitted with automatic thermal overload protection. This switches off the pump if it overheats. If this occurs, switch off the power at the mains supply to the pump. Check for the cause. Usually it will be debris blocking the inlets of the pump or obstructing the impeller. Remove the obstruction and wait 15 minutes for the pump to cool down and automatically reset. Then switch on the pump again.

**NOTE: YOU MUST SWITCH OFF THE MAINS SUPPLY BEFORE THE PUMP WILL RESET.**

Titan 5500 - Hmax 3.8m

Titan 8000 - Hmax 4.0m

From **1st January 2005** installing this product in the garden is classed as 'notifiable' in the revised Building Regulations for England and Wales. The Regulations now require you to tell your local authority building control department that you intend to install this product before installation. Your local authority will let you know how you can get your installation approved.

The pump is electrically operated and is designed to pump solid particles up to 8mm in diameter with minimal pre-strainer maintenance. These types of pumps are particularly suitable for pumping water to external filters or for use in high flow waterfalls or water course applications where low maintenance is important. The pump does not use oil or grease for lubrication and can be used safely in ponds containing fish or plants. The motor consists of a sealed stator and water-cooled rotor. All electrical components are isolated from the water.

### WARNING: SAFETY AND ELECTRICAL CONNECTIONS.

1. The pump is supplied with 10m of 3 core electric cable which is permanently connected and sealed to the motor.

The supply cable cannot be replaced. If the cable is damaged, the pump should be discarded.

This product is designed to be permanently wired to the mains supply in a dry weatherproof enclosure through a Double-Pole Switched Fused Spur - with a minimum contact gap of 3mm - (Disconnecter) to BS 3676 - Fitted with a 3 or 5 Amp fuse.

The installation must conform to the regulations of the National and Local wiring regulations which could include the use of plastic or metal conduit to protect the cable.

2. A 10mA or 30mA Residual Current Device (RCD) Must be fitted to the mains supply.
3. **WARNING:** This appliance must be earthed and it is essential that the connections are made using the following code;

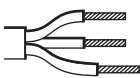

Brown - Live

Blue - Neutral

Green/Yellow - Earth

The BROWN lead should be connected to the LIVE terminal which may be marked with an 'L' or coloured brown or red.

The BLUE lead should be connected to the NEUTRAL terminal which may be marked with an 'N' or coloured blue or black.

The GREEN/YELLOW lead should be connected to the EARTH terminal which may be marked with an 'E' (⊕) or coloured green or green/yellow.

4. If an extension cable is required, this should be connected to the end of the pump cable using a weatherproof cable connector. The joint must be positioned in a suitable dry housing. The extension cable should be of 3 core 0.75mm<sup>2</sup> Polychloroprene rubber insulated cable (ref: HO5 RN-F) and permanently wired to the mains supply with a 3 or 5 Amp fuse.
5. The pump cable (and extension cable) should be positioned and adequately protected against damage especially where contact with gardening equipment, (lawn mowers,

forks etc..) children and domestic animals may occur.

6. Consult a qualified electrician or local authority if in any doubt about wiring to the mains supply.
7. The maximum head values of these pumps are: Titan 5500 - 3.8m, Titan 8000 - 4.0m.

### IMPORTANT

1. **WARNING:** Always unplug or disconnect all appliances in the pond from the electricity supply before putting your hands in the water whilst equipment is being installed, repaired, maintained or handled.
2. Do not use the supply cable to lift the pump, as this may cause damage. We recommend fitting a lifting cord to the handle on the top of the strainer cage when the pump is installed in deep water.
3. Do not operate or leave the pump in freezing conditions.
4. Do not allow the pump to run dry.
5. Do not operate this pump without the strainer cage attached. Using the pump without a filter may invalidate your warranty.

### PUMP ASSEMBLY.

1. Un-pack the ball joint assembly (A in Fig 1) from the accessory pack.
2. Rotate the three lid latching knobs to the open position and lift the Strainer Cage Top from the Strainer Base (B in Fig 1).
3. Firmly pull the pump out of its location (C in Fig 1).
4. Checking that the ball joint's inlet and outlet bosses are in line, offer the female threaded nut to the male threaded pump chamber outlet (D in Fig 1) and firmly screw them together.
5. Place the pump back into the location, reposition the lid and rotate the lid latching knobs back to the locked position.

### PUMP INSTALLATION.

**ATTENTION: This product is not suitable for water temperatures above 35°C**

#### Position

1. For the best results, the pump should be positioned in the deepest part of the pond. This

will ensure the best circulation of water in the pond and when being used as a Filtration pump, its solids handling capability will be maximised.

**Waterfall or Pond Filter Only.**

1. Using small bore hoses leads to excessive restriction of the water flow. The larger the diameter of hose that you use the better the performance of the pump will be, especially over long hose runs. The Hose tail supplied with this unit will accommodate 19mm (3/4"), 25mm (1"), 32mm (1.25") and 38mm (1.5") hose. **We would always recommend that on pumps of this size, that the 38mm diameter hose should be used.** Once you have selected the hose diameter you wish to use, cut the steps off the Hose tail which are smaller than the hose diameter to eliminate restriction (Fig 2). Attach a suitable length hose to the Threaded Hose tail and secure with a suitable hose clip and position the outlet end of the hose in the desired position.

2. Screw the Threaded Hose tail directly onto the outlet boss of the ball joint (E in Fig 1). The ball joint can be rotated to allow the hose to be directed away from the pump. Position the pump as previously described.

**Wildlife Protection System.**

If you have fish or other wildlife in your pond, there are periods in the year during which they may breed. At this time the fish 'fry' are small and can be sucked into the pump. To minimise this possibility, the Titan range of pumps has a unique Wildlife Protection System which allows you to reduce the inlet strainer hole size down to 2mm at this critical time in a fishes life cycle, by moving the lever on the side of the Strainer Cage (F in Fig1).

During the period when the aperture size is reduced, you may need to unblock the Strainer Cage more frequently. Once the fish or other wildlife have grown to a sufficient size you can then return the aperture size to its maximum 10mm size.

**MAINTENANCE.**

The Hozelock Cyprio range of Titan pumps have been designed to allow fast and easy maintenance. As with all pumps of its kind, occasionally it will become necessary to clean the Strainer Cage.

Always unplug or disconnect ALL appliances in the pond from the electricity supply before putting your hands in the water or starting maintenance.

**Strainer.**

1. Unscrew the Threaded Hose tail from the pump outlet (E in Fig 1).
2. Rotate the three lid latching knobs to the open position and lift the Strainer Cage Top from the Strainer Base (B in Fig 1).
3. Firmly pull the pump out of its location using the handle and wash/rinse the Strainer Cage with clean water.
4. Reassemble the pump.

**Rotor Assembly. (See Fig. 1)**

1. Remove the Strainer Cage as described above.
2. Release the Pump Chamber (G) by rotating it until the two retaining tongues are clear of the lugs on the Motor Body.
3. Gently pull the Pump Chamber squarely away from the Motor Body (C).
4. Pull the Rotor Assembly (H) out of the Motor Body.
5. Wash out all of the components in clean water. Do not use detergents or other chemical cleaners.

6. Replace the Rotor Assembly into the Motor Body and refit the Pump Chamber and Strainer Cage.

**ALL YEAR PUMP CARE.**

A quick daily check should be carried out to ensure that the pump is performing satisfactorily. Once a month- Remove and clean the Strainer Cage in accordance with the general maintenance notes. Depending on pond water conditions, cleaning may be required more frequently.

Once a year- Completely disassemble the pump including the Rotor Assembly as described in the general maintenance instructions and wash all components in clean, fresh water. Replace worn or broken parts.

**SPARE PARTS.**

Contact the Consumer Services Helpline on 0870 850 1959

	Part No.	
	5500	8000
<b>Spares</b>		
1. Pump Chamber Assembly and Seal.	Z13437	Z13437
2. Rotor Assembly.	Z13466	Z13467
3. Strainer Cage Assembly.	Z13436	Z13436
4. Threaded Outlet Adapter.	1470	1470
5. Ball Joint	Z13515	Z13515

**HOZELOCK CYPRIO 3 YEAR GUARANTEE.**

If this pump, excluding the Rotor Assembly, becomes unserviceable within 3 years of the date of purchase it will be repaired or replaced at our option free of charge, unless in our opinion it has been damaged or misused.

Liability is not accepted for damage due to accident, improper installation or use. Liability is limited to replacement of a faulty pump. This guarantee is not transferable. It does not affect your statutory rights.

To obtain the benefits of the guarantee, firstly contact Hozelock Cyprio Consumer Services who may request that the pump is sent along with proof of purchase directly to the address below.

**Hozelock Cyprio**  
 Midpoint Park, Birmingham  
 B76 1AB, England  
 Tel: 0870 850 1959  
 www.hozelock.com

FAULT FINDING.	
Important - Please keep this section for reference.	
LOW FLOW FROM PUMP	<ol style="list-style-type: none"> <li>1. Ensure the Strainer Cage is clean.</li> <li>2. A small diameter outlet pipe will restrict outlet flow.</li> </ol>
NO FLOW FROM PUMP	<ol style="list-style-type: none"> <li>1. Check the power supply is on.</li> <li>2. Check the fuse and wiring.</li> <li>3. Check the Rotor Assembly is not jammed , damaged or showing signs of excessive wear.</li> <li>4. Ensure the Strainer Cage is clean.</li> <li>5. The Thermal Protection has tripped. (see first paragraph).</li> </ol>



**Hozelock Cyprio**  
Midpoint Park  
Birmingham  
B76 1AB  
England  
Tel: 0870 850 1959  
[www.hozelock.com](http://www.hozelock.com)

The Aquatics Division of Hozelock Group

33622-001

